

**COLOR TELEVISION**

***SERVICE MANUAL***

**21” T2S08 CHASSIS  
WITH NICAM&TELETEXT**

---

**CONTENTS**

---

|  |    |
|--|----|
| I SAFETY PRECAUTION .....                        | 1  |
| II SPECIFICATION .....                           | 2  |
| III IC'S GENERAL DESCRIPTION .....               | 3  |
| IV SPECIAL IC INTRODUCTION .....                 | 3  |
| V CHASSIS BLOCK DIAGRAM .....                    | 12 |
| VI SERVICE MODE&ADJUSTMENT .....                 | 13 |
| VII TEST POINT WAVE FORM&SCHEMATIC DIAGRAM ..... | 18 |

# I SAFETY PRECAUTION

## 1. X-RAY RADIATION PRECAUTION

1.1 Excessive high voltage can produce potentially hazardous X-RAY RADIATION. To avoid such hazards the high voltage must be specified limit. The normal value of the high voltage of this receiver is  $27KV \pm 500V$  under 230V AC power source. The high voltage must not exceed 30KV.

1.2 Each time a receiver requires servicing the high voltage should be checked following the HIGH VOLTAGE CHECK procedure in this manual. It is recommended the reading of the high voltage be recorded as a part of the service record. It is important to use an accurate and reliable high voltage meter.

1.3 The primary source of X -RAY RADIATION in this TV receiver is the picture tube. For continued X-RAY RADIATION protection, the replacement tube must be exactly the same type tube as used in this TV receiver.

1.4 Some parts in this receiver have special safety-related characteristics for X-RAY RADIATION protection. For continued safety, parts replacement should be undertaken only after referring the PRODUCT SAFETY NOTICE below.

## 2. GENERAL SAFETY PRECAUTION

The following are the necessary precautions to be observed before servicing this chassis

**WARNING:** Service should not be attempted by anyone unfamiliar with the necessary

2.1 Since the power supply circuit of this receiver is directly connected to the AC power line. An isolation transformer should be used during any dynamic service to avoid possible shock hazard.

2.2 Always discharge the picture tube anode to the CRT conductive coating before handling the picture tube. The picture tube is highly evacuated and if broken, glass fragments will be violently expelled. Use shatterproof goggles and keep picture tube away from the unprotected body while handling.

2.3 When replacing a chassis in the cabinet, always be certain that all the protective devices are put back in place, such as: nonmetallic control; knobs, insulating covers, shields, isolation resistor-capacitor, network, etc.

2.4 Connection wires must be kept away from components with high voltage or high temperature.

2.5 When replacing parts or circuit boards, disconnect the power cord.

2.6 When replacing a high voltage resistor (metal oxide resistor) on circuit board, keep the resistor APP. 10mm (1/2 in.) away from circuit board.

2.7 If any fuse in this TV receiver is broken, replace it with the FUSE specified in the chassis parts list.

2.8 The receiver is designed to operate with 230V (50Hz) AC mains.

## 3. PRODUCT SAFETY NOTICE

Many electrical and mechanical parts in this chassis have special safety-related characteristics are often passed unnoticed by a visual inspection and the X-RAY RADIATION protection afforded by them cannot necessarily be obtained by using replacement components rated for higher voltage. The use of substitute replacement parts that do not have the same safety characteristics as specified in the parts list may create shock, fire, X-RAY RADIATION or other hazards.

### **Warning!**

There are no any repairable components in this TV set. Do not try to make any change to it. High voltage inside may cause danger.

## II SPECIFICATION

|                   |  |
|-------------------|--|
| RF SYSTEM         | COLOR SYSTEM: PAL SECAM<br>SOUND SYSTEM: B/G D/K I NICAM STEREO  |
| VIDEO SYSTEM      | PAL SECAM NTSC4.43   |
| TUNING SYSTEM     | VOLTAGE SYNTHESIZER TUNING   |
| RECEIVING CHANNEL | VHF-L: E2~S6      48.25 MHz~140.25MHz<br>VHF-H: S7~S36    147.25 MHz~423.25MHz<br>UHF: S37~DS57   431.25 MHz~863.25MHz |
| PROGRAM PRESET    | 99   |
| AV JACKS          | 1 SIDE RCA AV IN<br>1 FULL SCART AND 1 AV SCART  |
| TELETEXT          | 1PAGE  |
| ANTENNA INPUT     | 75Ω (UNBALANCE)  |
| AUDIO OUTPUT      | ≥2.5W  |
| MAIN POWER        | 170-260V AC 50/60Hz  |
| POWER CONSUMPTION | 100W   |

## III CHIP GENERAL DESCRIPTION

### 1. MAIN BOARD PART

|       |            |  |
|-------|------------|--|
| IC001 | ST92195    | MCU With ON SCREEN DISPLAY and TELETEXT Decoder                        |
| IC002 | 24C08      | 8 Kbit Serial I <sup>2</sup> C Bus EEPROM                              |
| IC101 | STV2246    | I <sup>2</sup> C BUS-Controlled Multistandard Single Chip TV Processor |
| IC301 | STV9306A/B | BUS-Controlled VERTICAL DEFLECTION W.E/W CORRECTION CIRCUIT            |
| IC601 | H11A817C   | OPTOCOUPERS  |
| IC603 | MC7808CT   | +8V VOLTAGE REGULATOR  |
| IC604 | MC7805CT   | +5V VOLTAGE REGULATOR  |
| IC605 |            |  |
| IC606 | MC7812CT   | +12V VOLTAGE REGULATOR   |
| IC701 | CD7522CS   | 3W AUDIO AMPLIFIER   |
| IC801 | STV8216    | Multi-standard TV Audio Processor and Digital Sound Demodulator        |

## IV CHIP INTRODUCTION

### 1. ST92195

The ST92195 microcontrollers are developed and manufactured by STMicroelectronics using a proprietary n-well HCMOS process. Their performance derives from the use of flexible 256-register programming model for ultra-fast context switching and real-time event response. The intelligent on-chip peripherals offload the ST9 core from I/O and data management processing tasks allowing critical application tasks to get the maximum use of core resources. The ST92195 MCU support low power consumption and low voltage operation for power-efficient and low-cost embedded systems.

#### 1.1 Main features

28 fully-programmable I/Os

4 channels Analog/Digital Converter

Built in I<sup>2</sup>C bus interface

Built in OSD and Teletext decoder

14-bit Voltage Synthesis PWM output for VS tuning system

## 1.2 Pin description

| Pin No. | Pin Name | Signal Name | I / O | Function                                      |
|---------|----------|-------------|-------|---|
| 1       | P2.0     | IRIN        | I     | IR Input                                      |
| 2       | RESET    | RESET       | I     | Hardware Reset                                |
| 3       | P0.7     | NC          | I/O   | Not Used                                      |
| 4       | P0.6     | MUTE        | O     | Mute Output PIN                               |
| 5       | P0.5     | NC          | I/O   | Not Used                                      |
| 6       | P0.4     | ON/OFF      | O     | Standby Output                                |
| 7       | P0.3     | DESIGN      | I     | Service menu control                          |
| 8       | P0.2     | SCART1      | I     | Identify scart entering Design                |
| 9       | P0.1     | SCART2      | I     | Identify scart entering Design                |
| 10      | P0.0     | AV SEL      | O     | AV Selection                                  |
| 11      | P3.7     | S0          | O     | AV/TV   |
| 12      | P3.6     | S1          | O     | AV/TV   |
| 13      | P3.5     | TV/DVD      | O     | TV/DVD  |
| 14      | P3.4     | DFD         | O     | Default data control                          |
| 15      | B        | B           | O     | OSD Blue colour Signal Output                 |
| 16      | G        | G           | O     | OSD Green colour Signal Output                |
| 17      | R        | R           | O     | OSD Red colour Signal Output                  |
| 18      | BLANK    | BLANK       | O     | OSD Blanking Output                           |
| 19      | P5.1     | SDA         | I/O   | I <sup>2</sup> C data line                    |
| 20      | P5.0     | SCL         | O     | I <sup>2</sup> C clock line                   |
| 21      | VDD      | VDD         |       | +5 V Digital Supply                           |
| 22      | JTDO     | JTDO        |       | Test Pin                                      |
| 23      | WSCF     | WSCF        |       | Analog Pin For VPS / WPP slicer line PLL      |
| 24      | WSCR     | WSCR        |       | Analog Pin For VPS / WPP slicer line PLL      |
| 25      | AVDD3    | AVDD3       |       | +5V Analog VDD For PLL                        |
| 26      | TEST0    | TEST0       |       | Test Pin                                      |
| 27      | MCFM     | MCFM        |       | Analog Pin for display pixel freq. multiplier |
| 28      | JTCK     | JTCK        |       | Test Pin                                      |
| 29      | TXCF     | TXCF        |       | Analog pin for VPS /WSS line PLL              |
| 30      | CVBSO    | CVBSO       |       | Test Pin                                      |
| 31      | AVDD2    | AVDD2       |       | Analog Power supply                           |
| 32      | JTMS     | JTMS        |       | Test Pin                                      |
| 33      | CVBS2    | CVBS2       | I     | CVBS In for VPS / WSS                         |
| 34      | CVBS1    | CVBS1       | I     | CVBS In for Teletext Slicer                   |
| 35      | AGND     | AGND        |       | Analog ground                                 |
| 36      | GND      | GND         |       | Digital ground                                |
| 37      | JTRST0   | JTRST0      |       | Test Pin                                      |
| 38      | PXFM     | PXFM        |       | Analog Pin for display pixel freq. multiplier |
| 39      | AVDD1    | AVDD1       |       | Analog Power Supply                           |
| 40      | HSYNC    | HSYNC       | I     | Horizontal Sync Input                         |
| 41      | VSYN     | VSYN        | I     | Vertical Sync Input                           |

|    |      |          |     |                        |
|----|------|----------|-----|------------------------|
| 42 | P4.0 | BSW1     | O   | Band switch 1          |
| 43 | P4.1 | BSW2     | O   | Band switch 2          |
| 44 | P4.2 | SAW_SW1  | O   | SAW Filter switch 1    |
| 45 | P4.3 | NC       | I/O | Not connected          |
| 46 | P4.4 | SAW_SW2  | O   | SAW Filter switch 2    |
| 47 | P4.5 | NC       | I/O | Not connected          |
| 48 | P4.6 | Vlin PWM | O   | V-linearity PWM output |
| 49 | P4.7 | VOL PWM  | O   | VOL PWM output         |
| 50 | XTAL | XTAL     |     | Clock oscillator       |
| 51 | XTAL | XTAL     |     | Clock oscillator       |
| 52 | P2.5 | LED2     | O   | LED driver             |
| 53 | P2.4 | LED1     | O   | LED driver             |
| 54 | P2.3 | VS       | O   | VST Voltage ouput      |
| 55 | P2.2 | NC       | I/O | Not connected          |
| 56 | P2.1 | KB INPUT | I   | KEY Input              |

### 1.3 Block diagram

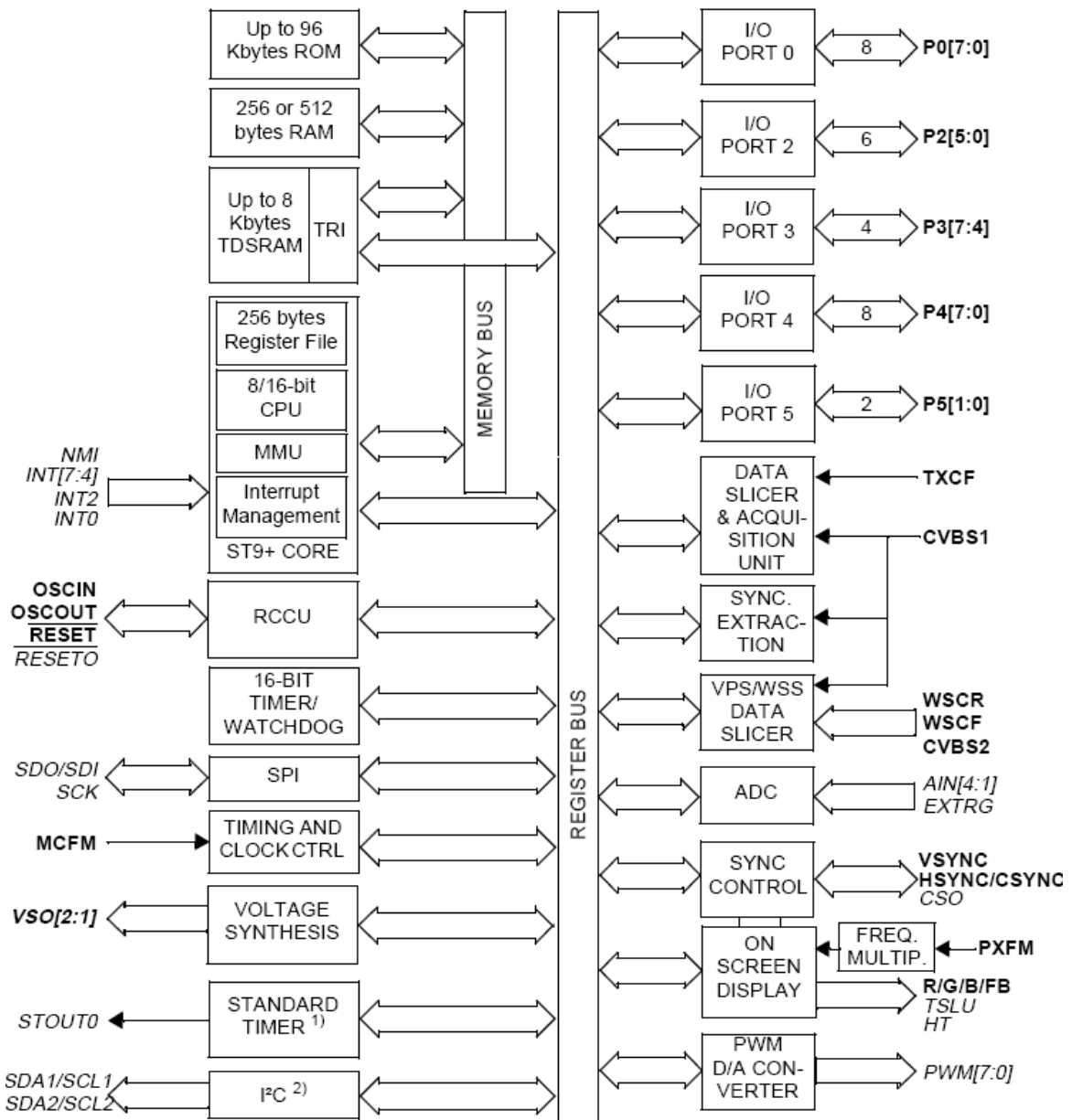

## 1.4 General application description

### BAND SWITCH OUTPUT (Pin42 Pin43)

| Pin42 BSW1 | Pin43 BSW2 | SELECTED BAND |
|------------|------------|---------------|
| 0          | 0          | NOT USED      |
| 0          | 1          | VHF-L         |
| 1          | 0          | VHF-H         |
| 1          | 1          | UHF           |

### KEYBOARD INPUT LEVEL (Pin56)

| KEY IN (Pin 56) | KEY PRESSED          |
|-----------------|----------------------|
| 0.285 ~ 0.587V  | Volume – (1 K ohm)   |
| 0.706 ~ 1.098V  | Volume + (2.2 K ohm) |
| 1.204 ~ 1.596V  | Program- (3.9 K ohm) |
| 1.704 ~ 2.096V  | Program+ (6.2 K ohm) |
| 2.194 ~ 2.586V  | MENU (9.1 Kohm)      |
| 2.704 ~ 3.096V  | TV/DVD (13.8 Kohm)   |
| 3.205 ~ 3.606V  | AV/TV(22 Kohm)       |
| 3.745 ~ 4.145V  | Analog (37.4 Kohm)   |
| 4.282 ~ 4.682V  | OK (86.5 K ohm)      |

Note: The pull up resistor of Pin56 is 10K.

### TV/AV SELECTION (Pin11/Pin12)

|            |    |         |     |       |
|------------|----|---------|-----|-------|
| S0-Pin11   | 0  | 1       | 0   | 1     |
| S1-Pin12   | 0  | 0       | 1   | 1     |
| TV/AV MODE | TV | AV1/RGB | AV2 | S-VHS |

### STANDBY OUTPUT (Pin6)

| STD-BY (Pin 6) | Mode      |
|----------------|-----------|
| 0              | Standby   |
| 1              | Operating |

## 2. STV2246H

The STV224XH is fully bus-controlled IC for TV that include PIF, SIF, Luma, Chroma and Deflection processing functions. Used with a vertical frame booster (TDA8174A for a 90° chassis, STV9306 for a 110° chassis), they allow multi-standard (BG/DK/I/MN/LL', PAL/SECAM/NTSC) sets to be designed with very few external components and no manual adjustments.

### 2.1 Main features

I<sup>2</sup>C Bus Control

PIF Circuit with PLL Demodulation (Positive and Negative Video)

SIF Circuit with QSS Structure, FM Demodulation and AM Demodulation for France

Intercarrier Capability and Built-in Sound Band pass

Sound Subcarrier Output for Stereo Chassis (FM, NICAM)

Integrated Chroma Filters and Luma Delay Line and Integrated Chroma Delay Line

3 channels input Video Switch and 2 channels CVBS output

OSD RGB Inputs and external RGB Inputs Interface

PAL/SECAM/NTSC Chroma Demodulators

Black Stretch and peaking Circuit

Automatic Cut-off Current Loop, manual Cut-off possible for low-cost applications

Two Horizontal Deflection PLLs

APR (Automatic RGB Peak Regulation) or RGB Peak Limitation Function

## 2.2 Pin description

| PIN NO. | SYMBOL             | DESCRIPTION                                      |
|---------|--------------------|--|
| 1       | SIFIN1             | SIF input  |
| 2       | SIFIN2             | SIF input  |
| 3       | AGCSIFCAP          | AGC SIF capacitor                                |
| 4       | V <sub>REFIF</sub> | Voltage reference filter                         |
| 5       | AGCPIFCAP          | AGC PIF capacitor                                |
| 6       | PIFIN1             | PIF input  |
| 7       | PININ2             | PIF input  |
| 8       | TUNERAGCOUT        | AGC Tuner output                                 |
| 9       | IFPLL              | IF PLL filter                                    |
| 10      | GND <sub>IF</sub>  | IF Ground  |
| 11      | AM/FMOUT/SC        | AM/FM Mono sound or stereo carriers output       |
| 12      | VCC <sub>IF</sub>  | 5V IF Supply                                     |
| 13      | INTCVBSOUT         | Internal CVBS output                             |
| 14      | EXTAUDIOIN         | External audio input                             |
| 15      | PIFLC1             | LC input   |
| 16      | PIFLC2             | LC input   |
| 17      | V <sub>CC2</sub>   | Video/LUMA Supply voltage (8V)                   |
| 18      | CVBSIN1            | Internal video input                             |
| 19      | GND2               | Video/LUMA ground                                |
| 20      | CVBSIN2            | External video input                             |
| 21      | BS                 | Black stretch capacitor                          |
| 22      | Y/CVBSIN3          | Y(SVHS) or CVBS3 external input                  |
| 23      | CHR                | Chroma(SVHS) input                               |
| 24      | APR                | Automatic RGB peak regulation                    |
| 25      | BEXT/Cb            | External blue input or Cb input                  |
| 26      | GEXT/Y             | External green input or Y input                  |
| 27      | REXT/Cr            | External red input or Cr input                   |
| 28      | FBEXT              | External fast blanking input                     |
| 29      | NC/CVBSOUT1        | Not connected or CVBS output1                    |
| 30      | BOUT               | Blue output                                      |
| 31      | GOUT               | Green output                                     |
| 32      | ROUT               | Red output                                       |
| 33      | I <sub>CATH</sub>  | Cathode current measurement input                |
| 34      | BOSD               | OSD Blue input                                   |
| 35      | GOSD               | OSD Green input                                  |
| 36      | ROSD               | OSD Red input                                    |
| 37      | FBOSD/HC           | OSD Fast blanking input/half contrast            |
| 38      | XTAL3/BTUN         | 3.5x MHz Crystal or bell filter tuning capacitor |
| 39      | XTAL2              | 3.5x MHz Crystal                                 |
| 40      | XTAL1              | 4.43/3.5x MHz Crystal                            |

|    |                  |   |
|----|------------------|---|
| 41 | CLPF             | Chroma PLL filter   |
| 42 | X1/VAMP/CHROUT   | XTAL1 control pin, vertical amplitude DAC output and chroma reference signal output |
| 43 | GND1             | Chroma/scanning ground  |
| 44 | CVBSOUT2         | Second video switch output  |
| 45 | V <sub>CC1</sub> | Chroma/scanning power supply (8V)   |
| 46 | BCL/SAF          | Beam current limiter control voltage and safety input(X-ray)                        |
| 47 | VERT             | Vertical output pulse   |
| 48 | HOUT             | Horizontal output pulse   |
| 49 | LFB/SSC          | Line flyback input and super-sandcastle output                                      |
| 50 | SLPF             | Scanning PLL filter   |
| 51 | SCL              | I <sup>2</sup> C Bus clock input  |
| 52 | SDA              | I <sup>2</sup> C Bus data input   |
| 53 | V <sub>CCD</sub> | Digital supply voltage(5V)  |
| 54 | GNDD             | Digital ground  |
| 55 | AUDIOOUT         | Main audio output   |
| 56 | FMCAP            | FM demodulation capacitor   |

## 2.3 Block diagram

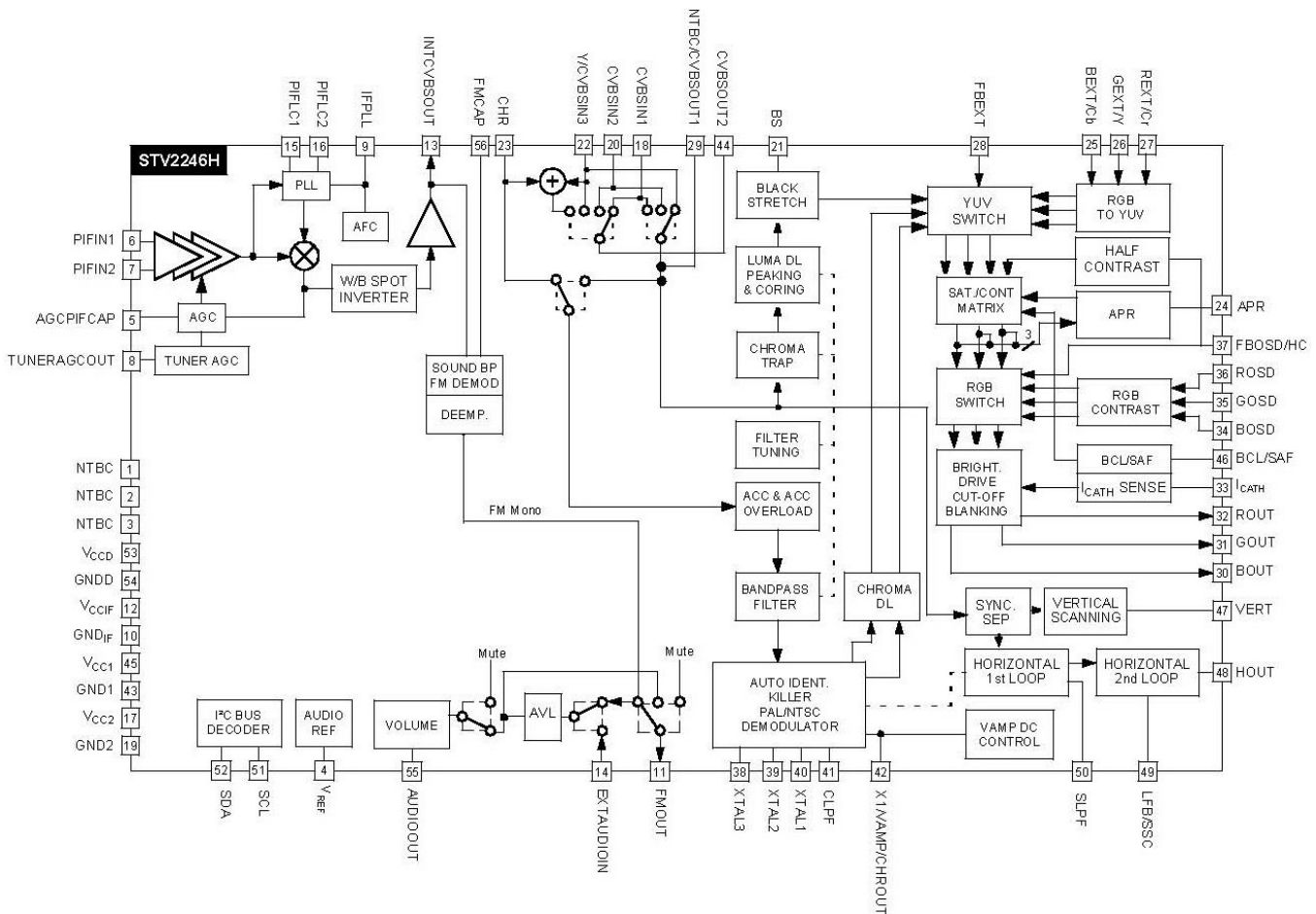

## 3. STV9306A

The STV9306 is a fully I<sup>2</sup>C controlled vertical deflection IC designed for use in 110°, 4/3 or 16/9 CRT applications. It integrates both the vertical deflection and E/W correction circuitries necessary in design of a 110° chassis.

### 3.1 Main features

Fully I<sup>2</sup>C controlled

Internal flyback generator (UPTO60V) and DC Coupled operation

Self adapted sawtooth (50/60Hz)

Vertical linearity, amplitude and centering adjustments.

Horizontal width, pincushion, trapezoid and corner adjustments. Breathing correction.

### 3.2 Pin description

| PIN NO. | SYMBOL    | DESCRIPTION                  |
|---------|-----------|------------------------------|
| 1       | SCL       | I <sup>2</sup> C Bus clock   |
| 2       | CRAMP     | Ramp capacitor               |
| 3       | SDA       | I <sup>2</sup> C Bus data    |
| 4       | CHOLD     | Hold capacitor               |
| 5       | SYNC      | Sync input                   |
| 6       | VS        | Supply voltage               |
| 7       | FLYBACK   | Flyback output               |
| 8       | GND       | Vertical output              |
| 9       | OUT       | Vertical output              |
| 10      | VOPS      | Vertical output Power Supply |
| 11      | EWOUT     | EW output                    |
| 12      | SENS2     | Vertical current sense2      |
| 13      | EWFB      | EW feedback                  |
| 14      | SENS1     | Vertical current sense1      |
| 15      | BREATHING | Breathing input              |

### 3.3 Block diagram

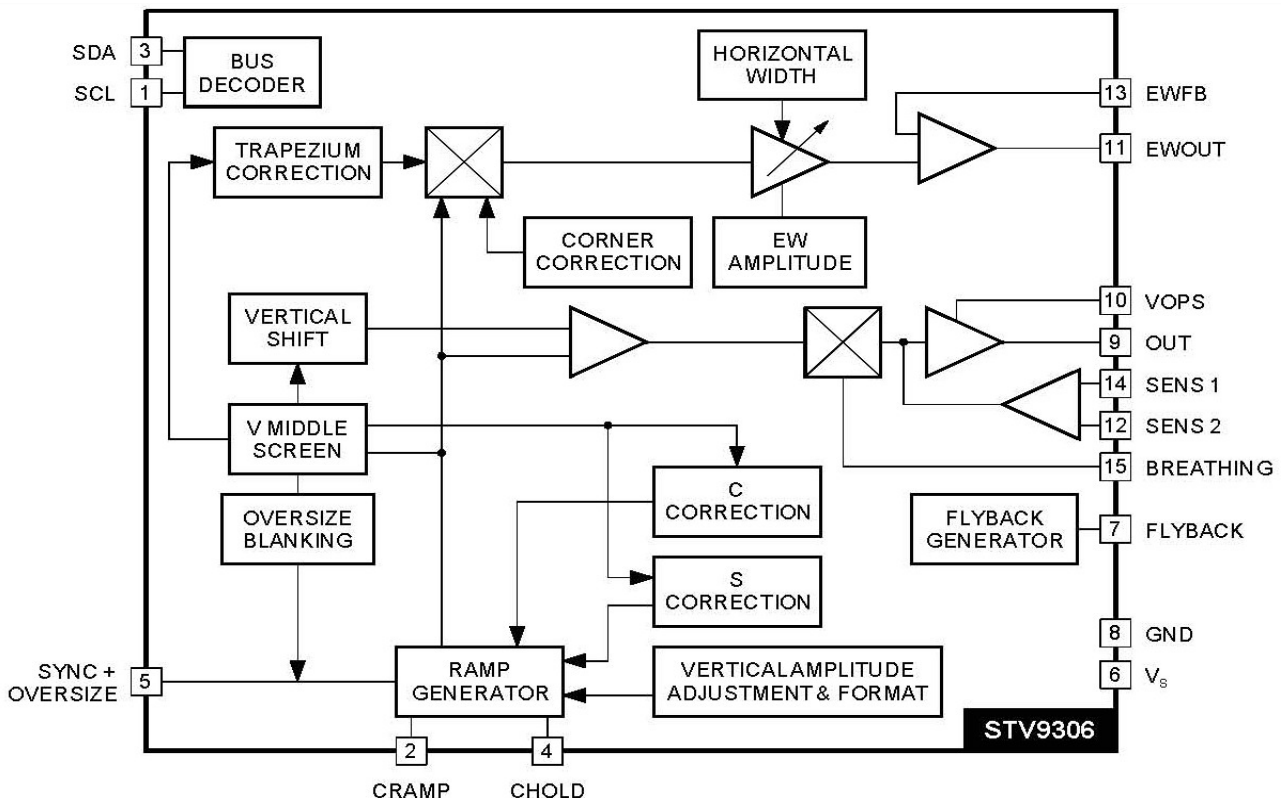

## 4. CD7522CS

The CD7522CS is a stereo 2×3W BTL audio amplifier, specially designed for high quality sound TV applications. Features of the CD7522CS include Stand-by and Volume control functions.

### 4.1 Main feature

2×3W output power  $R_L = 8\Omega$  @THD = 0.5%  $V_{CC} = 10V$

Standby and volume control function

Low turn-on turn-off pop noise

Low voltage supply  $\leq 14V$

Thermal overload protection

### 4.2 Pin description

| Pin NO. | SYMBOL | DESCRIPTION       |
|---------|--------|-------------------|
| 1       | VCC    | Power supply      |
| 2       | OUT1+  | Ch1 output +      |
| 3       | GND    | Gnd (output ch1)  |
| 4       | OUT1-  | Ch1 output -      |
| 5       | ST-BY  | Standby control   |
| 6       | Ch1 In | Ch1 audio output  |
| 7       | GND    | Gnd (Input)       |
| 8       | Ch2 In | Ch2 audio output  |
| 9       | Vol    | DC volume control |
| 10      | OUT2-  | Ch2 output -      |
| 11      | GND    | Gnd (output ch2)  |
| 12      | OUT2+  | Ch2 output +      |
|         |        |                   |
|         |        |                   |
|         |        |                   |

### 4.3 Block diagram

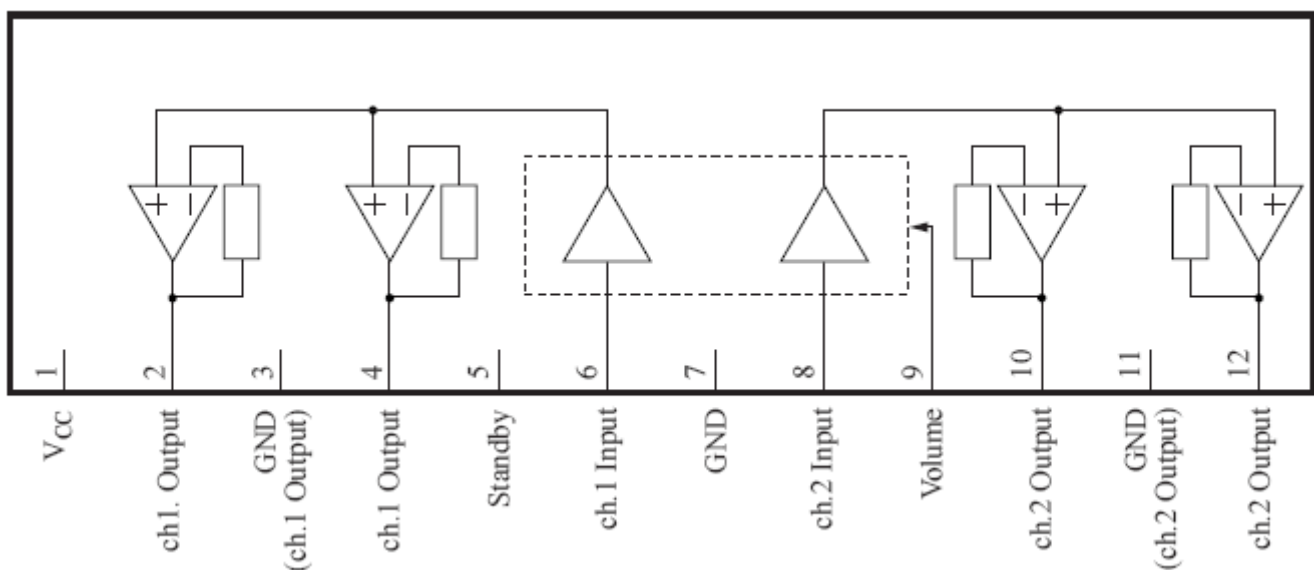

## 5. STV8216

This chip included three main parts:

**TV Sound Demodulator:** provides all the necessary circuitry for the demodulation of audio transmissions of European and Asian terrestrial TV broadcasts. The various transmission standards are automatically detected and demodulated without user intervention.

**Audio Processor:** based on DSP technology independently controls loudspeaker, subwoofer and headphone signals. It offers basic and advanced features, such as a ST Wide Surround, Equalizer, Automatic Loudness and Smart Volume Control for television viewer comfort. The STV8226/36 versions can perform additionally the SRS 3D Surround for stereo and mono signals.

**Audio Matrix:** 3 stereo and 1 mono external analog audio inputs to loudspeakers and headphone, with 2 stereo external analog audio outputs (SCART compatible).

### 5.1 Main features

NICAM, AM, FM Mono and FM 2 carrier stereo demodulators for all sound carriers between 4.5 and 7MHz

Mono input provided for optimum AM demodulation performances

Demodulation controlled by automatic standard recognition system

Sound IF AGC with wide range, over modulation and carrier offset recovery,

Smart volume control, smart volume control, 5-band equalizer bass/treble control, automatic loudness control

Loudspeaker and Headphone outputs with volume/balance controls and beeper

Subwoofer output with volume control and programmable bandwidth, spatial Sound Effects (ST Wide Surround and Pseudo-Stereo), low-noise audio mutes and switches

I<sup>2</sup>C Bus-controlled, single and standard 27 MHz crystal oscillator,

Power supplies: 3.3V Digital, 5V or 8V Analog, embedded 3.3V regulators

### 5.2 Pin description

| Pin NO. | SYMBOL            | Pin TYPE            | DESCRIPTION  |
|---------|-------------------|---------------------|--|
| 1       | SIF               | Analog              | Sound IF input   |
| 2       | VTOP              | Analog              | ADC VTOP decoupling pin  |
| 3       | VREF IF           | Analog              | AGC Voltage reference decoupling Pin                                 |
| 4       | VDD <sub>IF</sub> | Analog power supply | 3.3V Power supply for IF AGC & ADC                                   |
| 5       | GNDIF             | Analog power supply | Ground for IF AGC & ADC  |
| 6       | MONOIN            | Analog              | Mono Input   |
| 7       | AO1L              | Analog              | Left SCART1 audio output   |
| 8       | AO1R              | Analog              | Right SCART1 audio output  |
| 9       | VDDC              | Analog power supply | 3.3V Power supply for audio DAC/ADC                                  |
| 10      | GNDC              | Analog power supply | Ground for audio DAC/ADC   |
| 11      | AI1L              | Analog              | Left SCART1 audio input  |
| 12      | AI1R              | Analog              | Right SCART1 audio input   |
| 13      | VMC1              | Analog              | Switched V <sub>REF</sub> decoupling Pin for audio converters (VMCP) |
| 14      | VMC2              | Analog              | V <sub>REF</sub> decoupling Pin for audio converters (VMC)           |
| 15      | AI2L              | Analog              | Left SCART2 audio input  |
| 16      | AI2R              | Analog              | Right SCART2 audio input   |
| 17      | VDDA              | Analog power supply | 3.3 V power supply for audio buffers, matrix & bias                  |
| 18      | GNDAH             | Analog power supply | Ground for audio buffers and SCART                                   |
| 19      | AO2L              | Analog              | Left SCART2 Audio output   |

|    |        |                      |   |
|----|--------|----------------------|---|
| 20 | AO2R   | Analog               | Right SCART2 Audio output                                 |
| 21 | VDDH   | Analog power supply  | 8V/5V power supply for SCART and audio buffers            |
| 22 | VREFA  | Analog               | Voltage reference for audio buffers                       |
| 23 | AI3L   | Analog               | Left SCART3 audio input                                   |
| 24 | AI3R   | Analog               | Right SCART3 audio input                                  |
| 25 | BGAP   | Analog               | Bandgap voltage source decoupling                         |
| 26 | LSL    | Analog               | Left loudspeaker output                                   |
| 27 | LSR    | Analog               | Right loudspeaker output                                  |
| 28 | SW     | Analog               | Subwoofer output  |
| 29 | HPL    | Analog               | Left headphone output                                     |
| 30 | HPR    | Analog               | Right headphone output                                    |
| 31 | GNDSA  | Analog power supply  | Substrate analog/digital shield                           |
| 32 | HPD    | Bidirectional        | Headphone detection input (active low)                    |
| 33 | ADR    | Input                | Hardware I <sup>2</sup> C chip address control            |
| 34 | SCL    | Open drain           | I <sup>2</sup> C serial clock                             |
| 35 | SDA    | Open drain           | I <sup>2</sup> C serial data                              |
| 36 | REG    | Analog               | 5V power regulator control                                |
| 37 | RESET  | Input                | Hardware reset (active low)                               |
| 38 | YSCK   | Bidirectional        | System clock output                                       |
| 39 | MCK    | Bidirectional        | I <sup>2</sup> S master clock output                      |
| 40 | VDD1   | Digital power supply | 3.3V Power supply for digital core & IO cells             |
| 41 | GND1   | Digital power supply | Ground for digital core & IO cells                        |
| 42 | GNDSP  | Analog power supply  | Substrate analog/digital shield for clock-PLL             |
| 43 | XTI    | Input                | Crystal oscillator Input                                  |
| 44 | XTO    | Output               | Crystal oscillator output                                 |
| 45 | VDDP   | Analog power supply  | 3.3V power supply for analog PLL clock                    |
| 46 | GNDP   | Analog power supply  | Ground for analog PLL clock                               |
| 47 | GND2   | Digital power supply | Ground for digital core, DSPs & IO cells                  |
| 48 | VDD2   | Digital power supply | 3.3V power supply for digital core, DSPs & IO cells       |
| 49 | CKTST  | Input                | Must be connected to ground                               |
| 50 | SDO    | Bidirectional        | I <sup>2</sup> S bus data output                          |
| 51 | ST/SDI | Bidirectional        | Stereo detection output / I <sup>2</sup> S bus data input |
| 52 | WS     | Bidirectional        | I <sup>2</sup> S bus word select output                   |
| 53 | SCK    | Bidirectional        | I <sup>2</sup> S bus clock output                         |
| 54 | BUS1   | Bidirectional        | I <sup>2</sup> C bus expander output1                     |
| 55 | BUS0   | Bidirectional        | I <sup>2</sup> C bus expander output2                     |
| 56 | IRQ    | Bidirectional        | I <sup>2</sup> C status read request                      |

### 5.3 Block diagram



## VI SERVICE MODE&ADJUSTMENT

The Service-1 mode is entered by pressing the “SERVICE” key on remote control when the TV is in ON condition and not in any Menu mode. In service mode, by pressing “OK” key, Service-2 is accessed. by pressing “OK” key again, Service-3 is accessed. By pressing “PP” key, exit Service mode.

### 6.1 WHITE BALANCE ADJUSTMENT

The items within the Service-1 mode can be accessed using P+/P- keys and the selected item can be modified by using V+/V- keys. The parameters controlled in the Service-1 menu are :

- a) Red Gain ( 0 ... 63 )
- b) DC Red ( 0 .... 127)
- c) Green Gain ( 0 .... 63)
- d) DC Green ( 0 .... 127)
- e) Blue Gain ( 0 .... 63)
- f) DC Blue ( 0 .... 127)
- g) APR\_threshold (0....15)
- h) LOGO ( the first show the length of logo, and the followed is the logo)
- i) R-Cutoff (0...63)
- j) G-Cutoff (0...63)

The display of Service-1 menu is showed as follows:



### 6.2 VIF ADJUSTMENT

When in Service-1 menu ,if “OK” key is pressed , Service-2 menu appears and the display is as follows.The parameters controlled in the Service-2 menu are :

- a) Tuner AGC ( 0 ... 63 )
- b) Horizontal position 50 Hz( 0 ... 63)
- c) Vertical position 50 Hz (0...15)
- d) Vertical amplitude 50Hz (0...63)
- e) Vertical linearity 50Hz (0...63)
- f) Horizontal position 60 Hz( 0 ... 63)
- g) Vertical position 60 Hz (0...15)
- h) Vertical amplitude 60 Hz (0...63)
- i) Vertical linearity 60 Hz (0...63)
- j) Sub-Bright Maximum (0...63)
- k) Sub-Bright Minimum (0...63)
- l) Sub Tint (0...63)
- m) VCO Coarse ( 0 ... 15)
- n) VCO Fine ( 0 ... 127 )
- o) VCO Coarse L1( 0 ... 15)
- p) VCO Fine L1( 0 ... 127 )

| Service V2.0  |     |
|---------------|-----|
| Tuner AGC     | 47  |
| HPOS 50       | 31  |
| VPOS 50       | 08  |
| VAMP 50       | 56  |
| VLIN 50       | 36  |
| HPOS 60       | 33  |
| VPOS 60       | 09  |
| VAMP 60       | 62  |
| VLIN 60       | 38  |
| Bright Max    | 63  |
| Bright Min    | 00  |
| Sub Tint      | 32  |
| VCO Coarse    | 05  |
| VCO Fine      | 063 |
| VCO Coarse L1 | 12  |
| VCO Fine L1   | 058 |

VCO STATUS OK

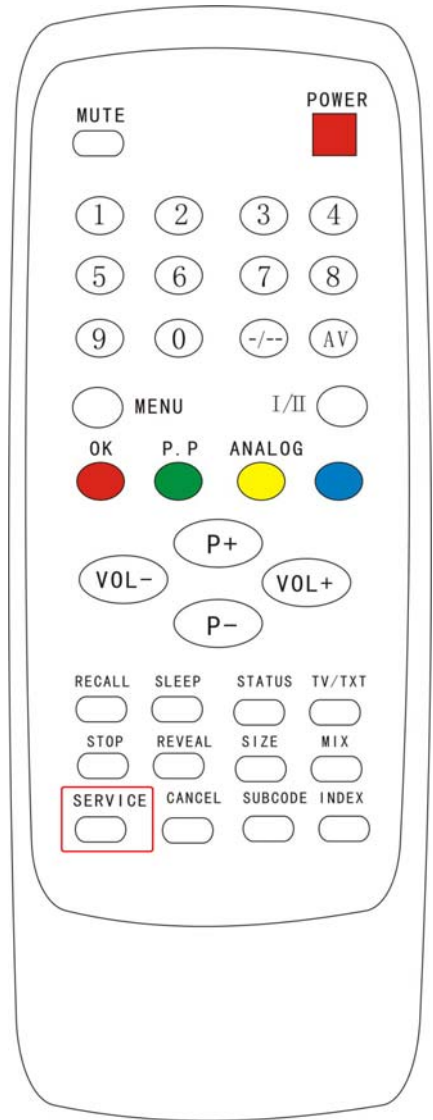

The display of Service-2 menu is showed as shown:

The VCO status bar at the bottom of the screen appears only if either VCO Coarse item or VCO Fine item is selected. The VCO status is read from the Read register of STV223X/4X and guides whether to Increase / Decrease the VCO registers to attain VCO OK Status.

For doing VCO adjustment , Feed a 38.9MHZ Carrier as IF input and adjust VCO Coarse and fine parameters to get VCO OK Status.

If the cursor is in VCO Coarse or Fine, and the display shows VCO OK status, then pressing of "AV" key will automatically put VCO fine to the Centre of the +60 to -60 KHz window.

For doing VCO L1 adjustment ,Feed a 33.9 MHz carrier as IF input and adjust VCO Coarse L1 and VCO Fine L1 to get VCO OK Status.

If the cursor is in VCO Coarse L1 or Fine L1 , and the display shows VCO OK status, then pressing of "AV" key will automatically put VCO fine for L1 to the Centre of the +60 to -60 KHz window.

Another fast way of adjustment of VCO is to put the selection bar to either VCO Coarse or fine and press the "AV" key. The VCO adjustment is done automatically. Similarly if you put the selection bar to VCO Coarse L1 or Fine L1 and press the "AV" key , the VCO L1 adjustment will be done automatically.

NOTE:Below items are not used in this chassis:

- Vertical position 50 Hz
- Vertical amplitude 50Hz
- Vertical linearity 50Hz
- Vertical position 60 Hz
- Vertical amplitude 60 Hz
- Vertical linearity 60 Hz

## 6.3 STV9306 ADJUSTMENT

When in Service-2 menu, if "OK" key is pressed, Service-3 menu appears and the display is as follows, if the IC STV9306 has not been detected, then Service-4 (design menu) menu will appear.

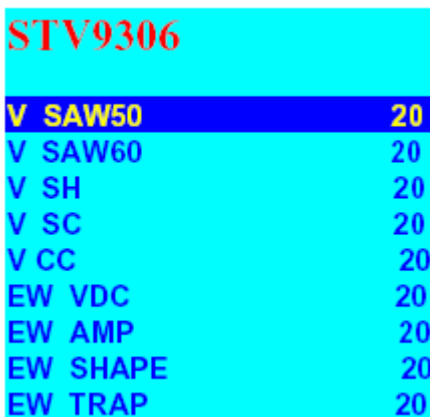

| STV9306  |    |
|----------|----|
| V SAW50  | 20 |
| V SAW60  | 20 |
| V SH     | 20 |
| V SC     | 20 |
| V CC     | 20 |
| EW VDC   | 20 |
| EW AMP   | 20 |
| EW SHAPE | 20 |
| EW TRAP  | 20 |

- 1) Vertical amplitude for 50Hz signal.
- 2) Vertical amplitude for 60Hz signal.
- 3) Vertical shift (internal separated by 50Hz and 60Hz)
- 4) S Correction.
- 5) C Correction.
- 6) Horizontal width adjustment.
- 7) Pincushion Correction.
- 8) E/W Sharp Correction.
- 9) Trapezium Correction.

## 6.4 DESIGN OPTION SETTING

When in Service-3 menu, if "OK" key is pressed, Option menu appears and the display is as follows:

| Design       |     |
|--------------|-----|
| AGC Gain     | 01  |
| Option1      | 50  |
| Option2      | 00  |
| Option3      | 15  |
| Option4      | 09  |
| Option5      | 00  |
| ST Ttxt      | 00  |
| HPOS OSD     | 001 |
| VPOS OSD     | 01  |
| HPOS TXT     | 057 |
| VPOS TXT     | 04  |
| HOTEL MODE   | OFF |
| Volume Limit | 32  |
| Sndst1       | 243 |
| Sndst2       | 03  |
| LLI MAGC     | OFF |

### OPTION1

b7 = Over modulation (0=Disable, 1=Enable, it's suggested to set it to 0 normally.)

b5 = P/N/S crystals application (0=2 Crystals, 1= 1 Crystals, according the quantity of crystal used for color decoding in chassis.)

b4 = Cutoff Loop (0= OFF, 1=ON, it's suggested to set it to 1 normally)

b3 = Safety Reset (0=Active, 1=Non, it's suggested to set it to 0 normally)

b2 = MONO IN (0 = OFF, 1= ON, Depend on the sound decoding solution used in chassis. )

b1 = Sound Demodulation (0 = Intercarrier/MONO, 1 =QSS/NICAM, depend on the sound decoding solution used in chassis.)

b0 = logo display (0 =OFF, 1= ON, it's suggested to set it to 0 normally.)

### OPTION2 (set to 0 by default)

b5 = HALF\_CONTRAST (0 = OFF, 1=ON)

b4 = Color 6dB (0 = OFF, 1 = ON)

b3 = APR Feature (0 = ON, 1= OFF)

b2 = Black Stretch (0 = ON, 1= OFF)

b1 = Auto Flesh (0 = ON, 1= OFF)

b0 = Coring (0 = ON, 1 = OFF)

### OPTION3

b7 =SMART (0 = OFF, 1=ON, it's suggested to set it to 1 normally)

b5 = AVL (0 = OFF, 1=ON, it's suggested to set it to 0 normally.)

b4 = PIF overmodulation (0 = OFF, 1= ON, it's suggested to set it to 0 normally.)

b3 = Market\_France --- secam LL (0 = OFF, 1 = ON, depend on the solution of chassis.)

b2 = Manual/Auto cutoff (0 = Manual, 1 = Auto cutoff, depend on the CRT for chassis.)

b1 = Mute pin low/high -to control the mute of speaker (0 = low, 1 = high, depend on the solution of chassis.)

### OPTION4

b6 = WIDE MODE (0 = OFF, 1=ON, it's suggested to set it to 0 normally.)

b4 = SCART2 (0 = OFF, 1=ON, depend on the solution of chassis.)

b3 = RGB (0 = OFF, 1= ON, depend on the solution of chassis.)

b2 = SVHS (0 = OFF, 1= ON, depend on the solution of chassis.)

b1 = AV2 (0 = OFF, 1= ON, depend on the solution of chassis.)

b0 = AV1 (0 = OFF, 1= ON, depend on the solution of chassis.)

## OPTION5

There are 8 bits used in OPTION 5. They are b0, b1, b2, b3, b4, b5, b6 and b7.

For b0, normally, ST suggests to set it to 0.

For b1, b2, they are used to select teletext languages.

For b3, it's used to enable AV3 and SVHS. When b3 is set to 0, SVHS is enabled. When b3 is set to 1 in binary, the value is 8 in decimal. AV3 is enabled.

For b4, b5, b6 and b7 of OPTION 5 are also used to set the brightness of background in teletext mode. When b4 b5 b6 and b7 are all set to 0, the brightness of teletext background is the same as brightness of TV background. When b4, b5, b6 and b7 are all set to 1, it's the maximum brightness of teletext background. It's the minimum brightness of teletext background when b4 is set to 1, and b5, b6 and b7 are all set to 0. you can set these 4 bits according to your favorite brightness of teletext background.

A. for 11 OSD languages CPU ST92195C7B1/MNS and ST92195C7B1/MTH for east Europe, the setting of the b1 and b2 is listed as below.

1. If b1 = b2 = 0, then the TEXT languages like "ENGLISH, FRENCH, SWEDISH, CZECH, GERMAN, PORTUGUESE (SPANISH), ITALIAN, RUMANIAN" can be decoded;
2. If b1=1, b2=0, then the TEXT languages like "ENGLISH, RUSSIAN (BULGARIAN), HUNGARIAN, TURKISH, GERMAN, PORTUGUESE (SPANISH), ITALIAN, RUMANIAN" can be decoded.
3. If b1=0, b2=1, then the TEXT languages like "POLISH, RUSSIAN (BULGARIAN), SWEDISH, SLOVAK, GERMAN, SLOVENIAN, LITHUANIAN, RUMANIAN" can be decoded.
4. If b1 = b2 =1, then the TEXT languages like "POLISH, RUSSIAN (BULGARIAN), SWEDISH, CZECH, GERMAN, CROATIAN, LETTISH, RUMANIAN" can be decoded.

B. for 12 OSD languages CPU ST92195C7B1/MNU and ST92195C7B1/MOK (SHRINK VERSION) for Western Europe, the setting of the b1 and b2 is as below.

1. If b1 = b2 = 0, then the TEXT languages like "ENGLISH, FRENCH, FINNISH, CZECH, GERMAN, PORTUGUESE (SPANISH), ITALIAN, GREEK" can be decoded;
2. If b1=1, b2=0, then the TEXT languages like "ENGLISH, FRENCH, DANISH, NORWEGIAN, GERMAN, PORTUGUESE (SPANISH), ITALIAN, GREEK" can be decoded.
3. If b1=0, b2=1, then the TEXT languages like "POLISH, FRENCH, SWEDISH, CZECH, HOLLAND, SERBIAN, ITALIAN, RUMANIAN" can be decoded.
4. If b1 = b2 =1, then the TEXT languages like "POLISH, FRENCH, SWEDISH, CZECH, GERMAN, PORTUGUESE (SPANISH), LETTISH, RUMANIAN" can be decoded.

## ST Text

b0 is used to change the process for adjusting Auto gain.

1) When CPU ST92195C7B1/MOK is used, the b0 is suggested to set to 0, the gain table for shrink version should be selected.

2) When CPU ST92195C7B1/MNU is used, the b0 is suggested to set to 1, the gain table for normal version will be selected.

b1, b2, b3 = select the correct process, only for ST engineer adjustment.

ROM\_M6\_P\_valid | OSDEPROM\_M6\_R\_valid | ROM\_M6\_R\_valid | EPROM\_M6\_R\_valid

EPROM\_M6\_R\_valid | ROMLESS\_H5\_P\_valid | ROM\_H5\_P\_valid | EPROM\_M6\_A\_valid

/\* note: ROMLESS\_M6\_R\_valid == ROM\_M6\_R\_valid\*/

b4 = Color transition for SVHS of STV224XX (0 = b5 is available, 1 = b5 is not available, and "SHARPNESS" is no feature.)

b5 = (0 = STV224XH, 1 = STV224XC/D/E).

b6 = Tuner Drift Correction (0 = OFF, 1 = ON.)

b7 = RGB/DVD display on screen (0 = RGB, 1 = DVD.)

**HPOS OSD,**

Adjust horizontal position of OSD.

**VPOS OSD,**

Adjust vertical position of OSD.

**HPOS TXT,**

Adjust horizontal position of teletext.

**VPOS TXT,**

Adjust vertical position of teletext.

**HOTEL MODE,**

To set HOTEL MODE ON or OFF. When HOTEL MODE is enabled. The end user can not make any adjustment of items in menu INSTALL, AUDIO and ORGANIZE. Menu INSTALL and AUDIO will disappear automatically.

**Volume Limit,**

To set maximum volume of HOTEL MODE. It's only available when HOTEL MODE is enabled.

**SndSt 1**

b0, b1, b2, b3 of SndSt 1 are used to set the sound output level at pin 26 and pin 27 of STV8216 with RF signal. When b0, b1, b2, b3 of SndSt 1 are all set 0, the minimum sound output level will be got at pin 26 and pin 27 of STV8216 with RF signal. When b0, b1, b2, b3 of SndSt 1 are all set 1, it's 15 in decimal. The maximum sound output level will be got at pin 26 and pin 27 of STV8216 with RF signal.

b4, b5, b6, b7 of SndSt 1 are used to set the "SURROUND" gain at pin 26 and pin 27 of STV8216 with RF & AV signal. When b4, b5, b6, b7 of SndSt 1 are all set 0, the minimum "SURROUND" gain will be got at pin 26 and pin 27 of STV8216 with RF & AV signal. When b4, b5, b6, b7 of SndSt 1 are all set 1, it's 240 in decimal. The maximum "SURROUND" gain will be got at pin 26 and pin 27 of STV8216 with RF signal.

**SndSt 2**

b0, b2, b2, b3 of SndSt 2 are used to set the sound output level at pin 26 and pin 27 of STV8216 with AV signal. When b0, b2, b2, b3 of SndSt 1 are all set 0, the minimum sound output level will be got at pin 26 and pin 27 of STV8216 with AV signal. When b0, b2, b2, b3 of SndSt 1 are all set 1, it's 15 in decimal. The maximum sound output level will be got at pin 26 and pin 27 of STV8216 with AV signal.

b4, b5, b6, b7 of SndSt 2 are used to set the "EQUALIZER" gain at pin 26 and pin 27 of STV8216 with RF & AV signal. When b4, b5, b6, b7 of SndSt 1 are all set 0, the maximum "EQUALIZER" gain will be got at pin 26 and pin 27 of STV8216 with RF & AV signal. When b4, b5, b6, b7 of SndSt 1 are all set 1, it's 240 in decimal. The minimum "EQUALIZER" gain will be got at pin 26 and pin 27 of STV8216 with RF & AV signal.

**LL1 MAGC,**

Just for SECAM LL1 SIF AGC setting purpose in STV8216. No available for PAL and NTSC system.

When the item "LL1 MAGC" is set to OFF, the SIF AGC of STV8216 is set by software.

When the item "LL1 MAGC" is set to ON, the SIF AGC of STV8216 can be set manually. The following steps can be followed when set this item.

- 1) To get a RF SECAM LL1 signal without sound modulation, only sound carrier is available. And put the signal to input of tuner in CTV 5 chassis.
- 2) To press "SERVICE" key on remote control to enter service menu. And select the item "LL1 MAGC" by P+ or P- key on remote control.

Set the item "LL1 MAGC" from "OFF" to "ON" by V+ or V- key on remote control.

**service command,**

- 1) "PP"----exit
- 2) "OK"---- switch between the service menu

- 3) "AV"---- auto VCO adjust
- 4) "MUTE" ---- one line gain

Enter service menu with user remote control,

- 1) Press key "Sleep" on remote control to set sleep time to "00:50".
- 2) Within 5 seconds, press local key "V+" in TV set to enter service menu.
- 3) Adjust expecting item as the same as service remote control.

## VII TEST POINT WAVE FORM&SCHEMATIC DIAGRAM

